

LEAF

For clean air in hazardous working environment

UNPARALLELED PROTECTION! LEAF - Standard Product Specifications

Leaf filtration systems are designed to provide 99.95% clean air in hazardous working environments. Its unique filtration method makes it reliable, economical and easy to handle.

Leaf filtration systems are available in 100, 200 (cubic feet per minute) CFM ranges. Specially designed 3-layer filtration enables complete removal of toxic gas and there by providing a safe working environment for the workers.

Specifications:

Configuration	Modular
Dimension	500 mm* 500 mm* 800 mm
Capacity	100 CFM
Operational efficiency	99.95% of the toxic gas generated
Filter lifecycle	100 operational Hours / 6 Months
Product lifecycle	5 Years

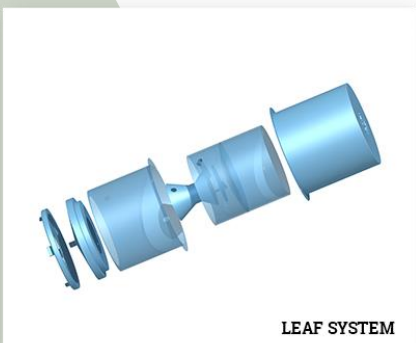

Typical Applications

- Industrial welding and/ soldering
- Chemical distributors
- Wood polish/ Paint shops
- Smoking rooms
- Abettor
- Laboratory air purification

Features and Benefits

- Low operating noise (< 75db)
- Low power consumption (300 W)
- Easily replaceable filters
- Effective treatment to remove a variety of toxic gases
- Continuous treatment at varying flow rates and concentrations
- Flexibility for installing multiple units in parallel and series for added capacity.